

Please take some time to enter and simulate this circuit for 100 ms (0.1 seconds). Note that you must give the capacitors initial conditions, and that you should turn OFF the initial bias point calculation.

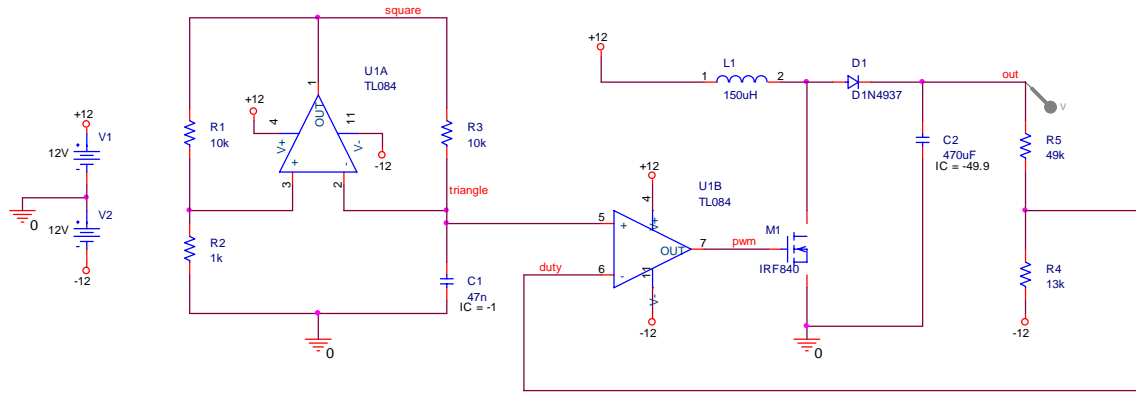

The simulation will take some time to complete, as there are many switching cycles to simulate. You should see that the voltage on the output stabilize.

Try and ask yourself the following questions:

1. Why are the values R4 and R5 not 12K and 50K?
2. What would the circuit do if the initial condition of C2 was 0V?